

**Motic®**

# **K-Series**

CMO Stereomicroscopes



## Introduction

The demands on stereomicroscopes have drastically changed over the last few years with new applications and advancements. A stereomicroscope is no longer limited to biological, geological or electronic component assembly applications. Moreover, a stereomicroscope must now have the capacity to document the task for further analysis or discussion.

Therefore, you require a stereomicroscope system, which provides the clearest image that is free of distortions, and allows you to document the process you have employed. Thus the new standard for stereomicroscopes can be segmented into three categories: Distortion-free imaging; Versatility in applications; and Information sharing.

### **K-Series Infinity Optical System Difference**

Employing a common main objective [CMO] infinity optical system, the Motic K-Series line of stereomicroscopes produce and showcase crisp, distortion-free, three-dimensional images. The CMO and infinity combination lower the fatigue of long term usage to ensure viewing is no longer a task in itself.

The brilliance of the CMO optical system is the utilisation of two parallel beams through a single objective. The final product is fatigue-free viewing which highlights the hidden information and detail to confirm or to uncover the answer to the question at hand.

Changing magnifications should be a trouble-free operation without you the user giving much thought to refocusing the image. The Motic K-Series line of stereomicroscopes arrive parfocal to minimise the down time between assembly and operation.

### **Versatility in Applications**

The K-Series line of stereomicroscopes, in response to ever-increasing applications, is available in three optical carriers to satisfy your specific magnification or method demand. Furthermore, the variety of accessories available provides you with options to expand the standard functions of the Motic K-Series stereomicroscope to fulfill other requirements you have. Finally, available in a modular format, the K-Series moulds itself to your application, because you select the additional components needed. Combining all these options, the Motic K-Series becomes your versatile stereomicroscope providing solutions for today's applications and the undiscovered applications of tomorrow.

### **Documentation and Discussion**

Documentation of your method or your findings is now standard practice in all industries. Stereomicroscopes are now required to photograph, film, or capture digital information of the specimen for further analysis elsewhere [computer or other research]. The K-Series line provides you the option to film, photograph, and digital integrate with your stereomicroscope. Utilising the same photo-video tube, for cost savings, the K-Series is ready to document. Further integration of the K-Series line is possible with Motic powerful digital application cameras and software, not only to extend the use of the stereomicroscope, but also to open new application solutions.



### **K-400 with 4 step magnification changer**

Infinity optics with 4-step magnifications of 6X, 12X, 25X and 50X, with 1 objective and 10X Super Widefield Eyepieces.

Four Standard Options:

- |        |   |
|--------|---|
| K-400P | Standard 1X Achromatic Objective with large working surface incident illumination stand and no built in illumination. |
| K-400L | Standard 1X Achromatic Objective with large working surface with built in transmitted and reflected illumination.     |
| K-401P | 1X Plan Achromatic Objective with large working surface incident illumination stand and no built in illumination.     |
| K-401L | 1X Plan Achromatic Objective with large working surface with built in transmitted and reflected illumination.         |

In today's ever-changing environment, combining infinity optics into a Common Main Objective [CMO] stereomicroscope system is not enough to satisfy the requirements of the day. With 3 different bodies and numerous stands and objective options, the K-Series line of stereomicroscopes delivers the versatility you need to overcome any dynamic requirement.



*The Motic K-Series line of stereomicroscopes provides you the best performance and versatility expected by your standards.*

## K-Series

### **K-500 with 5-step magnification changer**

Infinity optics with 5-step magnifications of 6.4X, 10X, 16X, 25X and 40X, with 1 objective and 10X Super Widefield Eyepieces.

Three Standard Options:

- |         |   |
|---------|---|
| K-500P  | Standard 1X Achromatic Objective with large working surface incident illumination stand and no built in illumination.                                 |
| K-500L  | Standard 1X Achromatic Objective with large working surface with built in transmitted and reflected illumination.                                     |
| DSK-500 | Dual discussion head complete unit with standard 1X Achromatic Objective and 1 specialised large working surface stand with no built in illumination. |

### **K-700 with zoom ratio 5.2 : 1**

Infinity optics with continuous zoom magnifications ranging from 6X to 31X, with 1 objective and 10X Super Widefield Eyepieces.

Three Standard Options:

- |         |   |
|---------|---|
| K-700P  | Standard 1X Achromatic Objective with large working surface incident illumination stand and no built in illumination.                                 |
| K-700L  | Standard 1X Achromatic Objective with large working surface and built in transmitted and reflected illumination.                                      |
| DSK-700 | Dual discussion head complete unit with standard 1X Achromatic Objective and 1 specialised large working surface stand with no built in illumination. |

Understanding all applications cannot always fit within the standard specifications, Motic offers its K-Series line of stereomicroscopes in a modular format to satisfy these requests. Whether you are using the K-Series in a surgical theatre or on an inspection station, the versatility and optical performance reassures a hassle-free fit into your system.

### K-SERIES HEADS WITHOUT ILLUMINATION

Designed for integration into existing systems or combined with other illumination options.

### K-SERIES HEADS WITH ILLUMINATION

Designed for incorporation on a boom stand or table clamp pole stand for foot space convenience or specific function requirement.

### K-SERIES for Machine Applications without Illumination.

Designed and envisioned to be mounted onto a bonder or inspection machine and combined with your existing illumination or the Motic MLC-150 cold light illumination.

#### K400HS

- ◆ 4-step magnification with values of 6X, 12X, 25X, and 50X.



#### K401HS

- ◆ 1X Plan Achromatic objective with 4-step magnification with values of 6X, 12X, 25X, and 50X.

#### K400HI

- ◆ 4-step magnification with values of 6X, 12X, 25X, and 50X.



#### K401HI

- ◆ 1X Plan Achromatic objective with 4-step magnification with values of 6X, 12X, 25X, and 50X.

#### K400HB

- ◆ 4-step magnification with values of 6X, 12X, 25X, and 50X.



#### K401HB

- ◆ 1X Plan Achromatic objective with 4-step magnification with values of 6X, 12X, 25X, and 50X.

#### K500HS

- ◆ 5-step magnification with values of 6.4X, 10X, 16X, 25X and 40X.



#### K500HI

- ◆ 5-step magnification with values of 6.4X, 10X, 16X, 25X and 40X.



#### K500HB

- ◆ 5-step magnification with values of 6.4X, 10X, 16X, 25X and 40X.



#### K700HS

- ◆ 1 : 5.2 zoom ratio



#### K700HI

- ◆ 1 : 5.2 zoom ratio



#### K700HB

- ◆ 1 : 5.2 zoom ratio



\*Please note power supply not included\*



K-500HS with Articulating Arm Boom Stand

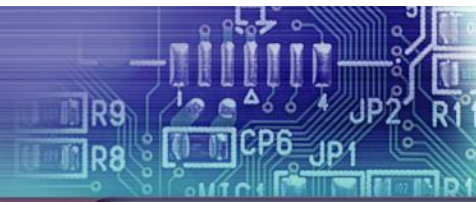

Regardless of your purpose for utilising the K-Series Line of stereomicroscopes, eventually you will need to discuss and to share the information you have uncovered. The K-Series offers several options from dual discussion systems to graphic sharing devices to photographic and digital documentation systems.

### DUAL DISCUSSION SYSTEMS

With a dual discussion system, you are able to train, share, and consult without the need to neither change location nor transport the specimen. Therefore saving you money, time, and foot space. The K-Series offers two versions of the dual discussion system to fulfill your requirements. Both systems facilitate dual discussion through the use of an optical bridge from the main body, which is mounted on a specialised large working surface stand, to the observation head.

#### DSK-500 DUAL DISCUSSION SYSTEM

- ◆ 5-step magnification with values at 6.4X, 10X, 16X, 25X, and 40X.
- ◆ 1X achromatic objective
- ◆ WF 10X / 21 mm



#### DSK-700 DUAL DISCUSSION SYSTEM

- ◆ Zoom magnification ratio of 5.2 : 1
- ◆ 1X achromatic objective
- ◆ WF 10X / 21mm

### DRAWING DEVICE

- ◆ Adjustable for right and left handed users
- ◆ Daylight observation capability
- ◆ Simultaneous visibility of sample and drawing surface
- ◆ Mirror in grids and specific documents for in depth observation



### DOCUMENTATION SYSTEMS

The K-Series offers you the option of two different methods to document your findings. Whether you prefer photographic or digital documentation, the K-Series has the necessary system.

#### Photographical Documentation

With the photographic documentation system, you have the option of choosing the standard 1501 system or customizing by adding the photo-focusing device 1502 for a better image quality.

#### 1501 - Standard Photo System

- ◆ The standard photo system is anchored by the double iris photo/video optical bridge [1500], which connects to the stereomicroscope between the binocular head and the optical body. The system then connects up to the photo eyepiece and the T2 phototube. The T2 phototube is screw mounted to the SLR camera.



#### 1500 Video-phototube



#### T2 phototube



#### 1502 - Focusing Phototube

- ◆ The focusing phototube is designed for the professional wanting a higher quality image. The tube replaces the T2 phototube in the standard 1501 photo system. The system utilises a diopter to adjust the clarity of the image along with a beam splitter, allowing you to align and focus the shot.



#### 1509 - Video/CCD System

- ◆ Utilising the same double iris optical bridge, the 1509 Video/CCD system allows for video imaging as well as digital documentation with the simple addition of a CS-mount. Motic's new line of 1/2" cameras require the new 0.65X adapter for proper imaging.



1509 Video/CCD System

## K400/401 Specifications

### K-400/K-401 Stereomicroscope Specifications

Optical system	Infinity Common Main Objective [CMO, Galilean]
Magnification changer	4-step, 6.0X, 12.0X, 25.0X, 50.0X
Standard magnification	6.0X - 50.0X
Magnification range	3.8X - 320.0X
Eyepieces	Super Widefield 10X / 23mm, 5X / 23mm, 6.25X / 23mm, 10X / 21mm, 20X / 13.4mm, 30X / 8mm, 32X / 8mm
Interpupillary distance	54mm - 76mm
Diopter adjustment	±5°
Observation angle	45°
Working distance	K400 - 89mm with Standard 1X Achromatic objective K401 - 110mm with 1X Plan Achromatic objective*
Optional objectives	K400 - Achromatic 0.3X, 0.5X, 0.625X, 1.5X, and 2X K401 - Achromatic 0.3X, 0.5X, 0.625X, 1.5X, and 2X
Max. field of view	127.8mm
<b>Accessories</b>	
Photographic documentation	Photo-equipment [1501.4] with T2-thread, photo eyepiece, focusing photo tube
Digital image documentation	CCD-equipment [1509.4] with C-mount, 1X, 0.65X, 0.45X, and 0.35X CCD adapter
Micrometer eyepieces	WF10X / 23mm (360° : 10° ) WF10X / 23mm (14mm : 0.2mm) WF10X / 23mm (14mm : 0.1mm) WF20X / 13.4mm (10mm : 0.1mm)
Drawing capability	Drawing Device [1508.4]
Polarisation capability	1-piece Rotary polarising set, Mountable 2-piece polarising set.
Darkfield capability	Darkfield attachment
<b>Stages, Illumination</b>	
Illumination	K2401 Fluorescent Ring Illumination, MLC-150 Cold Light Source, with flexible right light guide, 2 arm gooseneck type light guide, or 1 arm gooseneck type light guide 2410 Vertical illumination with 1402 Power supply
Focusing drive	Coarse and OEM bonder application
Incident illumination stand	Large working area
Transmitted-illumination stand	Brightfield [transmitted and reflected]
Universal stand	373 / 32mm column, 250 x 250mm base [2105S] 200 / 32mm column, 25mm diameter base [2105]
Articulating arm	600 / 32mm column, 260 x 260mm base [2107K] 600 / 32 mm column, table clamp version [2109K]
Ball bearing	600 / 32mm column, 260 x 260mm base [2108K] 600 / 32mm column, table clamp version [2110K]
Industrial arm stand	330mm column, Ø15.8mm nipple mount, 250 x 250mm base [2120K]
Stage	Gliding stage Mechanical Stage [rotary and plain]

\*1X Plan Achromatic objective must be selected at time of purchase [K401]

### Optical data of the K-400 Stereomicroscope

Eyepiece	Magnification changer position	Standard Objective 1.0X		* Plan Objective 1.0X		Auxiliary Objectives									
		Working Distance K400: 89mm		Working Distance K401: 110mm		0.3X		0.5X		0.625X		1.5X		2X	
		Total Mag.	Field Diameter	Total Mag.	Field Diameter	Total Mag.	Field Diameter	Total Mag.	Field Diameter	Total Mag.	Field Diameter	Total Mag.	Field Diameter	Total Mag.	Field Diameter
5X / 23	6.0	3.0X	38.3	3.0X	38.3	0.9X	127.8	1.5X	76.7	1.9X	61.3	4.5X	25.6	6.0X	19.2
	12.0	6.0X	19.2	6.0X	19.2	1.8X	63.9	3.0X	38.3	3.8X	30.7	9.0X	12.8	12.0X	9.6
	25.0	12.5X	9.2	12.5X	9.2	3.8X	30.7	6.3X	18.4	7.8X	14.7	18.8X	6.1	25.0X	4.6
	50.0	25.0X	4.6	25.0X	4.6	7.5X	15.3	12.5X	9.2	15.6X	7.4	37.5X	3.1	50.0X	2.3
6.25X / 23	6.0	3.8X	38.3	3.8X	38.3	1.1X	127.8	1.9X	76.7	2.3X	61.3	5.6X	25.6	7.5X	19.2
	12.0	7.5X	19.2	7.5X	19.2	2.3X	63.9	3.8X	38.3	4.7X	30.7	11.3X	12.8	15.0X	9.6
	25.0	15.6X	9.2	15.6X	9.2	4.7X	30.7	7.8X	18.4	9.8X	14.7	23.4X	6.1	31.3X	4.6
	50.0	31.3X	4.6	31.3X	4.6	9.4X	15.3	15.6X	9.2	19.5X	7.4	46.9X	3.1	62.5X	2.3
10X / 21	6.0	6.0X	35.0	6.0X	35.0	1.8X	116.7	3.0X	70.0	3.8X	56.0	9.0X	23.3	12.0X	17.5
	12.0	12.0X	17.5	12.0X	17.5	3.6X	58.3	6.0X	35.0	7.5X	28.0	18.0X	11.7	24.0X	8.8
	25.0	25.0X	8.4	25.0X	8.4	7.5X	28.0	12.5X	16.8	15.6X	13.4	37.5X	5.6	50.0X	4.2
	50.0	50.0X	4.2	50.0X	4.2	15.0X	14.0	25.0X	8.4	31.3X	6.7	75.0X	2.8	100.0X	2.1
10X / 23	6.0	6.0X	38.3	6.0X	38.3	1.8X	127.8	3.0X	76.7	3.8X	61.3	9.0X	25.6	12.0X	19.2
	12.0	12.0X	19.2	12.0X	19.2	3.6X	63.9	6.0X	38.3	7.5X	30.7	18.0X	12.8	24.0X	9.6
	25.0	25.0X	9.2	25.0X	9.2	7.5X	30.7	12.5X	18.4	15.6X	14.7	37.5X	6.1	50.0X	4.6
	50.0	50.0X	4.6	50.0X	4.6	15.0X	15.3	25.0X	9.2	31.3X	7.4	75.0X	3.1	100.0X	2.3
15X / 17.6	6.0	9.0X	29.3	9.0X	29.3	2.7X	97.8	4.5X	58.7	5.6X	46.9	13.5X	19.6	18.0X	14.7
	12.0	18.0X	14.7	18.0X	14.7	5.4X	48.9	9.0X	29.3	11.3X	23.5	27.0X	9.8	36.0X	7.3
	25.0	37.5X	7.0	37.5X	7.0	11.3X	23.5	18.8X	14.1	23.4X	11.3	56.3X	4.7	75.0X	3.5
	50.0	75.0X	3.5	75.0X	3.5	22.5X	11.7	37.5X	7.0	46.9X	5.6	112.5X	2.3	150.0X	1.8
20X / 13.4	6.0	12.0X	22.3	12.0X	22.3	3.6X	74.4	6.0X	44.7	7.5X	35.7	18.0X	14.9	24.0X	11.2
	12.0	24.0X	11.2	24.0X	11.2	7.2X	37.2	12.0X	22.3	15.0X	17.9	36.0X	7.4	48.0X	5.6
	25.0	50.0X	5.4	50.0X	5.4	15.0X	17.9	25.0X	10.7	31.3X	8.6	75.0X	3.6	100.0X	2.7
	50.0	100.0X	2.7	100.0X	2.7	30.0X	8.9	50.0X	5.4	62.5X	4.3	150.0X	1.8	200.0X	1.3
30X / 8	6.0	18.0X	13.3	18.0X	13.3	5.4X	44.4	9.0X	26.7	11.3X	21.3	27.0X	8.9	36.0X	6.7
	12.0	36.0X	6.7	36.0X	6.7	10.8X	22.2	18.0X	13.0	22.5X	10.7	54.0X	4.4	72.0X	3.3
	25.0	75.0X	3.2	7.5X	3.2	22.5X	10.7	37.5X	6.4	46.9X	5.1	112.5X	2.1	150.0X	1.6
	50.0	150.0X	1.6	150.0X	1.6	45.0X	5.3	75.0X	3.2	93.8X	2.6	225.0X	1.1	300.0X	0.8
32X / 8	6.0	19.2X	13.3	19.2X	13.3	5.8X	44.4	9.6X	26.7	12.0X	21.3	28.8X	8.9	38.4X	6.7
	12.0	38.4X	6.7	38.4X	6.7	11.5X	22.2	19.2X	13.0	24.0X	10.7	57.6X	4.4	76.8X	3.3
	25.0	80.0X	3.2	80.0X	3.2	24.0X	10.7	40.0X	6.4	50.0X	5.1	120.0X	2.1	160.0X	1.6
	50.0	160.0X	1.6	160.0X	1.6	48.0X	5.3	80.0X	3.2	100.0X	2.6	240.0X	1.1	320.0X	0.8

\*1X Plan Achromatic objective must be specified at time of purchase [K401] and cannot be added to the K400 system.

K-400L



# K500 Specifications

## K-500 Stereomicroscope Specifications

Optical system	Infinity Common Main Objective [CMO, Galilean]
Magnification changer	5-step, 6.4X, 10.0X, 16.0X, 25.0X, 40.0X.
Standard magnification	6.4X - 40.0X
Magnification range	1.2X - 256.0X
Eyepieces	Super Widefield 10X / 23mm, 5X / 23mm, 6.25X / 23mm, 10X / 21mm, 15X / 17.6mm, 20X / 13.4mm, 30X / 8mm, 32X / 8mm.
Interpupillary distance	54mm - 76mm
Diopter adjustment	±5°
Observation angle	45°
Working distance	89mm with standard 1X Achromatic objective
Optional objectives	Achromatic 0.3X, 0.5X, 0.625X, 1.5X and 2X.
Max. field of view	119.8mm
<b>Accessories</b>	
Photographic documentation	Photo-equipment [1501.3] with T2-thread, photo eyepiece, focusing photo tube.
Digital image documentation	CCD-equipment [1509.3] with C-mount, 1X, 0.65X, 0.45X and 0.35X CCD adapter.
Micrometer eyepieces	WF10X / 23mm (360° : 10° )
	WF10X / 23mm (14mm : 0.2mm)
	WF10X / 23mm (14mm : 0.1mm)
	WF20X / 13.4mm (10mm : 0.1mm)
Discussion capability	DSK-500 Dual Discussion Head
Drawing capability	Drawing Device [1508.3]
Polarisation capability	1-piece Rotary polarising set, Mountable 2-piece polarising set.
Darkfield capability	Darkfield attachment
<b>Stages, Illumination</b>	
Illumination	K2401 Fluorescent Ring Illumination, MLC-150 Cold Light Source, with flexible ring light guide, 2 arm gooseneck type light guide, or 1 arm gooseneck type light guide.
	2410 Vertical illumination with 1402 Power supply
Focusing drive	Coarse and OEM bonder application
Incident illumination stand	Large working area
Transmitted illumination stand	Brightfield [transmitted and reflected]
Universal stand	373 / 32mm column, 250 x 250mm base [2105S]
	200 / 32mm column, 25mm diameter base [2105]
Articulating arm	600 / 32mm column, 260 x 260mm base [2107K]
	600 / 32mm column, table clamp version [2109K]
Ball bearing	600 / 32mm column, 260 x 260mm base [2108K]
	600 / 32mm column, table clamp version [2110K]
Industrial arm stand	330mm column, Ø15.8mm nipple mount, 250 x 250mm base [2120K]
Stage	Gliding stage
	Mechanical stage [rotary and plain]



### Optical data of the K-500 Stereomicroscope

Eyepiece	Magnification changer position	Standard Objective 1.0X		Auxiliary Objectives									
				0.3X		0.5X		0.625X		1.5X		2X	
		Working Distance 89mm		Working Distance 236mm		Working Distance 148mm		Working Distance 111mm		Working Distance 43mm		Working Distance 25mm	
Nominal Magnification		Total Mag.	Field Diameter	Total Mag.	Field Diameter	Total Mag.	Field Diameter	Total Mag.	Field Diameter	Total Mag.	Field Diameter	Total Mag.	Field Diameter
5X / 23	6.4	3.2X	35.9	1.0X	119.8	1.6X	71.9	2.0X	57.5	4.8X	24.0	6.4X	18.0
	10.0	5.0X	23.0	1.5X	76.7	2.5X	46.0	3.1X	36.8	7.5X	15.3	10.0X	11.5
	16.0	8.0X	14.4	2.4X	47.9	4.0X	28.8	5.0X	23.0	12.0X	9.6	16.0X	7.2
	25.0	12.5X	9.2	3.8X	30.7	6.3X	18.4	7.8X	14.7	18.8X	6.1	25.0X	4.6
	40.0	20.0X	5.8	6.0X	19.2	10.0X	11.5	12.5X	9.2	30.0X	3.8	40.0X	2.9
6.25X / 23	6.4	4.0X	35.9	1.2X	119.8	2.0X	71.9	2.5X	57.5	6.0X	24.0	8.0X	18.0
	10.0	6.3X	23.0	1.9X	76.7	3.1X	46.0	3.9X	36.8	9.4X	15.3	12.5X	11.5
	16.0	10.0X	14.4	3.0X	47.9	5.0X	28.8	6.3X	23.0	15.0X	9.6	20.0X	7.2
	25.0	15.6X	9.2	4.7X	30.7	7.8X	18.4	9.8X	14.7	23.4X	6.1	31.3X	4.6
	40.0	25.0X	5.8	7.5X	19.2	12.5X	11.5	15.6X	9.2	37.5X	3.8	50.0X	2.9
10X / 21	6.4	6.4X	32.8	1.9X	108.2	3.2X	65.6	4.0X	52.5	9.6X	21.9	12.8X	16.4
	10.0	10.0X	21.0	3.0X	70.0	5.0X	42.0	6.3X	33.6	15.0X	14.0	20.0X	10.5
	16.0	16.0X	13.1	4.8X	43.8	8.0X	26.3	10.0X	21.0	24.0X	8.8	32.0X	6.6
	25.0	25.0X	8.4	7.5X	28.0	12.5X	16.8	15.6X	13.4	37.5X	5.6	50.0X	4.2
	40.0	40.0X	5.3	12.0X	17.5	20.0X	10.5	25.0X	8.4	60.0X	3.5	80.0X	2.6
10X / 23	6.4	6.4X	35.9	1.9X	119.8	3.2X	71.9	4.0X	57.5	9.6X	24.0	12.8X	18.0
	10.0	10.0X	23.0	3.0X	76.7	5.0X	46.0	6.3X	36.8	15.0X	15.3	20.0X	11.5
	16.0	16.0X	14.4	4.8X	47.9	8.0X	28.8	10.0X	23.0	24.0X	9.6	32.0X	7.2
	25.0	25.0X	9.2	7.5X	30.7	12.5X	18.4	15.6X	14.7	37.5X	6.1	50.0X	4.6
	40.0	40.0X	5.8	12.0X	19.2	20.0X	11.5	25.0X	9.2	60.0X	3.8	80.0X	2.9
15X / 17.6	6.4	9.6X	27.5	2.9X	91.7	4.8X	55.0	6.0X	44.0	14.4X	18.3	19.2X	13.8
	10.0	15.0X	17.6	4.5X	58.7	7.5X	35.2	9.4X	28.2	22.5X	11.7	30.0X	8.8
	16.0	24.0X	11.0	7.2X	36.7	12.0X	22.0	15.0X	17.6	36.0X	7.3	48.0X	5.5
	25.0	37.5X	7.0	11.3X	23.5	18.8X	14.1	23.4X	11.3	56.3X	4.7	75.0X	3.5
	40.0	60.0X	4.4	18.0X	14.7	30.0X	8.8	37.5X	7.0	90.0X	2.9	120.0X	2.2
20X / 13.4	6.4	12.8X	20.9	3.8X	69.8	6.4X	41.9	8.0X	33.5	19.2X	14.0	25.6X	10.5
	10.0	20.0X	13.4	6.0X	44.7	10.0X	26.8	12.5X	21.4	30.0X	8.9	40.0X	6.7
	16.0	32.0X	8.4	9.6X	27.9	16.0X	16.8	20.0X	13.4	48.0X	5.6	64.0X	4.2
	25.0	50.0X	5.4	15.0X	17.9	25.0X	10.7	31.3X	8.6	75.0X	3.6	100.0X	2.7
	40.0	80.0X	3.4	24.0X	11.2	40.0X	6.7	50.0X	5.4	120.0X	2.2	160.0X	1.7
30X / 8	6.4	19.2X	12.5	5.8X	41.7	9.6X	25.0	12.0X	20.0	28.8X	8.3	38.4X	6.3
	10.0	30.0X	8.0	9.0X	26.7	15.0X	16.0	18.8X	12.8	45.0X	5.3	60.0X	4.0
	16.0	48.0X	5.0	14.4X	16.7	24.0X	10.0	30.0X	8.0	72.0X	3.3	96.0X	2.5
	25.0	75.0X	3.2	22.5X	10.7	37.5X	6.4	46.9X	5.1	112.5X	2.1	150.0X	1.6
	40.0	120.0X	2.0	36.0X	6.7	60.0X	4.0	75.0X	3.2	180.0X	1.3	240.0X	1.0
32X / 8	6.4	20.5X	12.5	6.1X	41.7	10.2X	25.0	12.8X	20.0	30.7X	8.3	41.0X	6.3
	10.0	32.0X	8.0	9.6X	26.7	16.0X	16.0	20.0X	12.8	48.0X	5.3	64.0X	4.0
	16.0	51.2X	5.0	15.4X	16.7	25.6X	10.0	32.0X	8.0	76.8X	3.3	102.4X	2.5
	25.0	80.0X	3.2	24.0X	10.7	40.0X	6.4	50.0X	5.1	120.0X	2.1	160.0X	1.6
	40.0	128.0X	2.0	38.4X	6.7	64.0X	4.0	80.0X	3.2	192.0X	1.3	256.0X	1.0

# K700 Specifications

## K-700 Stereomicroscope Specifications

Optical system	Infinity Common Main Objective [CMO, Galilean]
Zoom ratio	5.2 : 1
Zoom magnification	6X - 31X
Magnification range	1.1X - 198.4X
Eyepieces	Super Widefield 10X / 23mm, 5X / 23mm, 6.25X / 23mm, 10X / 21mm, 15X / 17.6mm, 20X / 13.4mm, 30X / 8mm, 32X / 8mm
Interpupillary distance	54mm - 76mm
Diopter adjustment	±5°
Observation angle	45°
Working distance	89mm with standard 1X Achromatic objective
Optional objectives	Achromatic 0.3X, 0.5X, 0.625X, 1.5X and 2X
Max. field of view	127.8mm
<b>Accessories</b>	
Photographic documentation	Photo-equipment [1501.3] with T2-thread, photo eyepiece, focusing photo tube
Digital image documentation	CCD-equipment [1509.3] with C-mount, 1X, 0.65X, 0.45X, and 0.35X CCD adapter
Micrometer eyepieces	WF10X/23mm (360° : 10° )
	WF10X/23mm (14mm : 0.2mm)
	WF10X/23mm (14mm : 0.1mm)
	WF20X/13.4mm (10mm : 0.1mm)
Discussion capability	DSK-700Z Dual Discussion Head
Drawing capability	Drawing Device [1508.3]
Polarisation capability	1-piece Rotary polarising set, Mountable 2-piece polarising set.
Darkfield capability	Darkfield attachment
<b>Stages, Illumination</b>	
Illumination	K2401 Fluorescent Ring Illumination, MLC-150 Cold Light Source with flexible right light guide, 1 arm gooseneck type light guide, or 2 arm gooseneck type light guide
Focusing drive	Coarse and OEM bonder application
Incident illumination stand	Large working area [2112]
Transmitted illumination stand	Brightfield [transmitted and reflected] [2111]
Universal stand	373/32mm column, 250 x 250mm base [2105S]
	200/32mm column, 25mm diameter base [2105]
Articulating arm	600/32mm column, 260 x 260mm base [2107K]
	600/32 mm column, table clamp version [2109K]
Ball bearing	600/32mm column, 260 x 260mm base [2108K]
	600/32mm column, table clamp version [2110K]
Industrial arm stand	330mm column, ∅15.8mm nipple mount, 250 x 250mm base [2120]
Stage	Gliding stage
	Mechanical stage [rotary and plain]

### Optical data of the K-700 Stereomicroscope

Eyepiece	Magnification changer position	Standard Objective 1.0X		Auxiliary Objectives									
		Working Distance 89mm		0.3X		0.5X		0.625X		1.5X		2X	
		Total Mag.	Field Diameter	Total Mag.	Field Diameter	Total Mag.	Field Diameter	Total Mag.	Field Diameter	Total Mag.	Field Diameter	Total Mag.	Field Diameter
5X / 23	6.0	3.0X	38.3	0.9X	127.8	1.5X	76.7	1.9X	61.3	4.5X	25.6	6.0X	19.2
	10.0	5.0X	23.0	1.5X	76.7	2.5X	46.0	3.1X	36.8	7.5X	15.3	10.0X	11.5
	20.0	10.0X	11.5	3.0X	38.3	5.0X	23.0	6.3X	18.4	15.0X	7.7	20.0X	5.8
	31.0	15.5X	7.4	4.7X	24.3	7.8X	14.8	9.7X	11.9	23.3X	4.9	31.0X	3.7
6.25X / 23	6.0	3.8X	38.3	1.1X	127.8	1.9X	76.7	2.3X	61.3	5.6X	25.6	7.5X	19.2
	10.0	6.3X	23.0	1.9X	76.7	3.1X	46.0	3.9X	36.8	9.4X	15.3	12.5X	11.5
	20.0	12.5X	11.5	3.8X	38.3	6.3X	23.0	7.8X	18.4	18.8X	7.7	25.0X	5.8
	31.0	19.4X	7.4	5.8X	24.3	9.7X	14.8	12.1X	11.9	29.1X	4.9	38.8X	3.7
10X / 21	6.0	6.0X	35.0	1.8X	116.7	3.0X	70.0	3.8X	56.0	9.0X	23.3	12.0X	17.5
	10.0	10.0X	21.0	3.0X	70.0	5.0X	42.0	6.3X	33.6	15.0X	14.0	20.0X	10.5
	20.0	20.0X	10.5	6.0X	35.0	10.0X	21.0	12.5X	16.8	30.0X	7.0	40.0X	5.3
	31.0	31.0X	6.8	9.3X	22.6	15.5X	13.5	19.4X	10.8	46.5X	4.5	62.0X	3.4
10X / 23	6.0	6.0X	38.3	1.8X	127.8	3.0X	76.7	3.8X	61.3	9.0X	25.6	12.0X	19.2
	10.0	10.0X	23.0	3.0X	76.7	5.0X	46.0	6.3X	36.8	15.0X	15.3	20.0X	11.5
	20.0	20.0X	11.5	6.0X	38.3	10.0X	23.0	12.5X	18.4	30.0X	7.7	40.0X	5.8
	31.0	31.0X	7.4	9.3X	24.7	15.5X	14.8	19.4X	11.9	46.5X	4.9	62.0X	3.7
15X / 17.6	6.0	9.0X	29.3	2.7X	97.8	4.5X	58.7	5.6X	46.9	13.5X	19.6	18.0X	14.7
	10.0	15.0X	17.6	4.5X	58.7	7.5X	35.2	9.4X	28.2	22.5X	11.7	30.0X	8.8
	20.0	30.0X	8.8	9.0X	29.3	15.0X	17.6	18.8X	14.1	45.0X	5.9	60.0X	4.4
	31.0	46.5X	5.7	14.0X	18.9	23.3X	11.4	29.1X	9.1	69.8X	3.8	93.0X	2.8
20X / 13.4	6.0	12.0X	22.3	3.6X	74.4	6.0X	44.7	7.5X	35.7	18.0X	14.9	24.0X	11.2
	10.0	20.0X	13.4	6.0X	44.7	10.0X	26.8	12.5X	21.4	30.0X	8.9	40.0X	6.7
	20.0	40.0X	6.7	12.0X	22.3	20.0X	13.4	25.0X	10.7	60.0X	4.5	80.0X	3.4
	31.0	62.0X	4.3	18.6X	14.4	31.0X	8.6	38.8X	6.9	93.0X	2.9	124.0X	2.2
30X / 8	6.0	18.0X	13.3	5.4X	44.4	9.0X	26.7	11.3X	21.3	27.0X	8.9	36.0X	6.7
	10.0	30.0X	8.0	9.0X	26.7	15.0X	16.0	18.8X	12.8	45.0X	5.3	60.0X	4.0
	20.0	60.0X	4.0	18.0X	13.3	30.0X	8.0	37.5X	6.4	90.0X	2.7	120.0X	2.0
	31.0	93.0X	2.6	27.9X	8.6	46.5X	5.2	58.1X	4.1	186.0X	1.7	186.0X	1.3
32X / 10	6.0	19.2X	13.3	5.8X	44.4	9.6X	26.7	12.0X	21.3	28.8X	8.9	38.4X	6.7
	10.0	32.0X	8.0	9.6X	26.7	16.0X	16.0	20.0X	12.8	48.0X	5.3	64.0X	4.0
	20.0	64.0X	4.0	19.2X	13.3	32.0X	8.0	40.0X	6.4	96.0X	2.7	128.0X	2.0
	31.0	99.2X	2.6	29.8X	8.6	49.6X	5.2	62.0X	4.1	148.8X	1.7	198.4X	1.3



K-700L

# Illumination

How effective is a stereomicroscope without sufficient illumination? Stereomicroscopes, even equipped with infinity optics in a Common Main Objective [CMO] system, without the adequate illumination fail to accomplish the task at hand. The K-Series line of stereomicroscopes illumination is available in several options to effectively illuminate specimens from cell cultures to surface areas to integrated circuits to bonder welds to a simple geological sample.

## Transmitted Illumination

Standard illumination with K-Series L version

Ideally suited for cell culture, polarisation, geological, and translucent observations.

- ◆ 12V / 10W Halogen illumination with intensity control
- ◆ Available built in on stand 2111



## Reflected Illumination

Standard illumination with K-Series L version.

Ideally suited for providing a near darkfield imaging by casting illumination at an angle.

- ◆ 12V / 10W Halogen illumination with intensity control
- ◆ Available built in holder HI



## Vertical Illumination \*

Designed to prevent skewing shadows from tools placed within the beam path by directing illumination at an incident angle less than 5°.

- ◆ 2410 Vertical Illuminator - Special adapter to mount between the bottom of stereomicroscope and the objective [no affect on working distance]
- ◆ 1402 Power Supply



\*Not applicable with the K-700 line

## Inclined Incident Illumination

Ideally suited for oversized samples to investigate the specific detail of the sample in terms of contour and edges.

## K2401 Fluorescent Ring Illumination

Provides shadow-free, pure, white illumination for inspection and digital documentation.

Attachable to objective through the use of three mounting screws [included in the K2401] with the minimum amount of working distance consumption.

- ◆ 6400K - colour temperature
- ◆ 12W power consumption



## Ring Light Illumination with MLC-150 Cold Light

Suited for applications requiring the power supply to be located at a distance from the work area. Provides a cool, shadow-free, pure, white illumination for use in bonding equipment and boom stand applications.

Attachable to objective through the use of built in screws with the minimum amount of working distance consumption.

- ◆ Distal end diameter:  $\varnothing$  61mm
- ◆ 1,000mm - length of guide



## Bifurcated Light Guide with MLC-150 Cold Light Source

Suited for providing near darkfield by limiting the amount dark shadows on the sample. Adjustable to meet various applications and sample sizes, especially ideal for geological and semiconductor chip inspection.

- ◆ 500mm - length of each arm
- ◆ Gooseneck designed for adjustability



## MLC-150 Cold Light Source

Compact and powerful illumination source. Ideally suited for all applications requiring various illumination output. Built in colour temperature indication for light sensitive samples.

- ◆ 2500K - 3200K: colour range
- ◆ Remote or local intensity control
- ◆ 21V/ 150W switching power

A stereomicroscope is practical only if it allows itself to fit numerous applications and requirements. The line of stands available for the K-Series line of stereomicroscopes offer an array of choices to exceed the requirements.

### 2111 Transmitted Illumination Stand

Large working surface combined with 12V/10W halogen illumination stand.



### 2112 Basic Incident Illumination Stand

Large working area incident illumination stand



### 2105S Special Universal Stand

- ◆ Height of pole 373mm
- ◆ Length of base 250mm
- ◆ Width of base 250mm
- ◆ Diameter of mount 32mm



### 2105 Universal Stand

- ◆ Height of pole 373mm
- ◆ Diameter of base 200mm
- ◆ Diameter of mount 32mm



### 2107K Articulating Arm Boom Stand

- ◆ Height of pole 600mm
- ◆ Length of base 300mm
- ◆ Width of base 300mm
- ◆ Diameter of mount 32mm



### 2108K Ball Bearing Boom Stand

- ◆ Height of pole 600mm
- ◆ Length of base 300mm
- ◆ Width of base 300mm
- ◆ Diameter of mount 32mm



### 2109K Articulating Arm Boom Stand

- ◆ Height of pole 600mm
- ◆ Diameter of mount 32mm
- ◆ Table Clamp Type



### 2110K Ball Bearing Boom Stand

- ◆ Height of pole 600mm
- ◆ Diameter of mount 32mm
- ◆ Table Clamp Type



### 2105I Industrial Arm Boom Stand

- ◆ Width of base 250mm
- ◆ Length of base 250mm
- ◆ Height of pole 330mm
- ◆ Horizontal Movement 400mm
- ◆ Nipple Mount Diameter  $\varnothing$  15.8mm



## Stages / Contrast

The longevity of any stereomicroscope is found in the variety of accessories available to conform to the constantly changing requirements.

### STAGES

Stages serve the purpose of conveniently changing the location of inspection without losing sight of the specimen. With two types of stages to choose from, the requirements of the day can be effectively completed.

#### Gliding Stage

Easily attachable to the standard K-Series stands 2111 and 2112 bases; the gliding stage provides a hand movable, 360° rotary stage for various observations.



### LIGHT CONTRAST

Different methods of light contrast produce a variety of information. The K-Series offers you the option of viewing your specimen in two light contrasts other than brightfield for a thorough investigation of the specimen.

#### Darkfield Attachment

A base stand mountable darkfield attachment allows further detail of a specimen's structure through the utilisation of diffracted light observation.

- ◆ Conical glossy central stop
- ◆ Iris diaphragm for controlling the shape of light



### MECHANICAL STAGE

Base stand attachable, the mechanical stage becomes a movable working area to efficiently inspect, document, and discuss the specimen. There are two options for the mechanical stage for you to choose from.

- ◆ Maximum X movement: 76mm
- ◆ Maximum Y movement: 50mm
- ◆ Dimensions: 222.8mm x 170mm x 29.5mm

#### Basic Mechanical Stage

Base stand attachable mechanical stage with plain working surface to accommodate large or irregular objects.



### POLARISATION

With two options for polarisation, the K-Series facilitates the ability to investigate the birefringence of geological samples and the potential stress fracture in translucent material.

#### Mountable 2-piece Polarising Set

- ◆ Body screw mountable polariser
- ◆ Base stand mountable 360° rotary analyser.



#### Rotary Centre Mechanical Stage

Base stand mountable mechanical stage with a rotary centre sample holder for 360° observations.



#### 1-piece Rotary Polarising Set

- ◆ Base stand mountable
- ◆ 360° independently rotary polariser [top]
- ◆ 360° independently rotary analyser [bottom]





Requirements change in terms of working distance and magnification. Auxiliary eyepieces and objectives provide convenient and easy additions to the K-Series line of stereomicroscopes for adaptation to said changes.

### EYEPIECES

The K-Series offers seven different eyepiece options in addition to the standard Widefield 10X, field number 23mm, to increase either the magnification or working field of view.

- ◆ Widefield 5X, field number 23mm [1300]
- ◆ Widefield 6.25X, field number 23mm [1301]
- ◆ Widefield 10X, field number 21mm [2302]
- ◆ Widefield 15X, field number 17.6mm [1303]
- ◆ Widefield 20X, field number 13.4mm [1304]
- ◆ Widefield 30X, field number 8mm [1307]
- ◆ Widefield 32X, field number 8mm [1308]



### MICROMETER EYEPIECES

With four options for visual quantification, the K-Series micrometer eyepieces elevate the practicality of the stereomicroscope from a simple inspection instrument to an instantaneous quantification instrument.

- ◆ Widefield 10X, field number 23mm, 360° : 10° [2305.1]
- ◆ Widefield 10X, field number 23mm, 14mm : 0.2mm [2305.2]
- ◆ Widefield 10X, field number 23mm, 14mm : 0.1mm [2305.3]
- ◆ Widefield 20X, field number 13.4mm, 10mm : 0.1mm [1306]

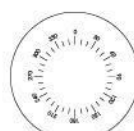

10X/23mm  
360° : 10°



10X/23mm  
14mm : 0.2mm



10X/23mm  
14mm : 0.1mm



20X  
10mm : 0.1mm

### AUXILIARY OBJECTIVES

Versatility of a stereomicroscope is defined by its ability to change working distances and magnifications as different applications are presented. Five different auxiliary objective options for either working distance or magnifications is the versatility of the K-Series.

#### K400/500/700 SYSTEMS

- ◆ 0.3X, Working Distance 236mm
- ◆ 0.5X, Working Distance 148mm
- ◆ 0.625X, Working Distance 111mm
- ◆ 1.5X, Working Distance 43mm
- ◆ 2.0X, Working Distance 25mm



#### K401 SYSTEM \*

- ◆ 0.3X, Working Distance 315mm
- ◆ 0.5X, Working Distance 194mm
- ◆ 0.625X, Working Distance 161mm
- ◆ 1.5X, Working Distance 59mm
- ◆ 2.0X, Working Distance 40mm



\* Specifically designed for the K401 system and cannot be interchanged with any other system.

# K400 L/P Schematic Diagram

Unit:mm

K-400L

K-400P

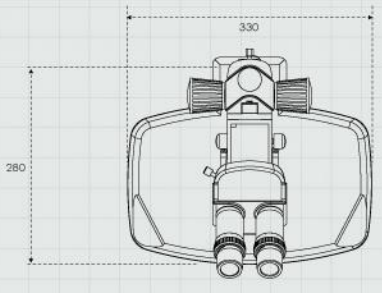
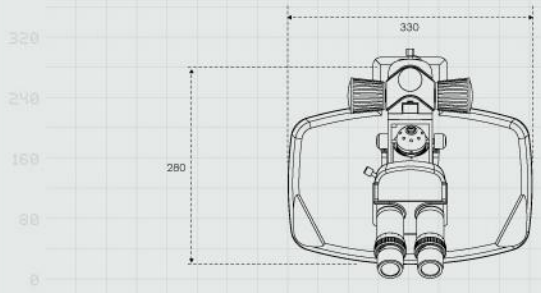
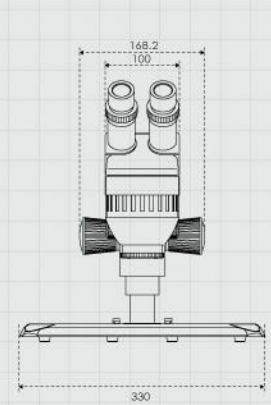
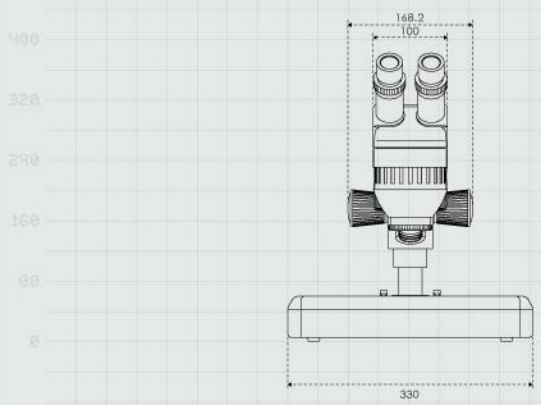
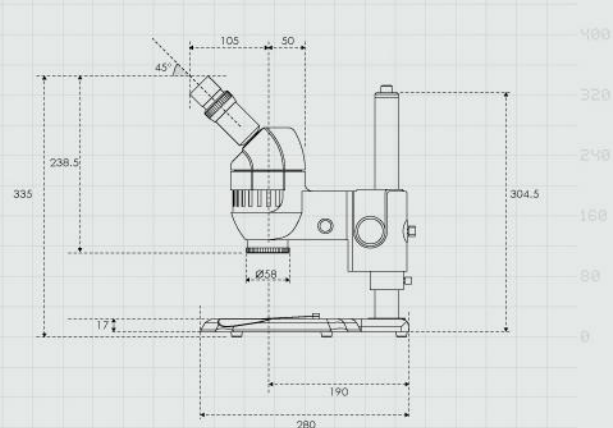
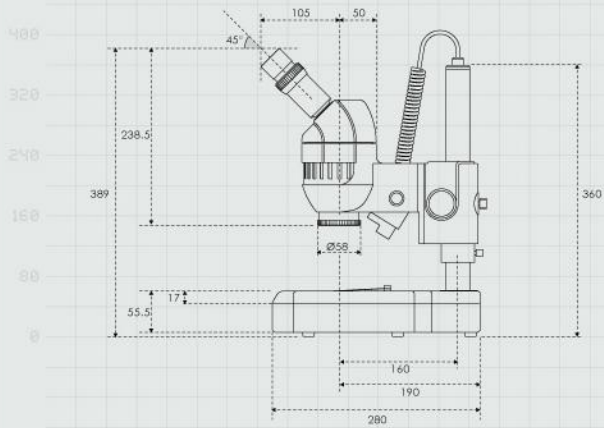





## K401 L/P Schematic Diagram

Unit:mm

### K-401L

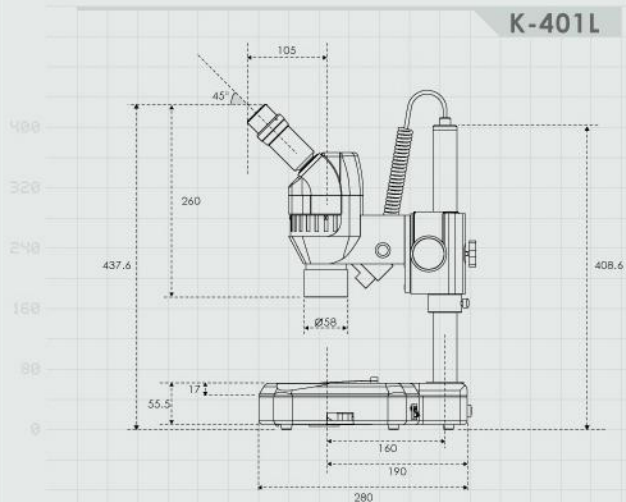

### K-401P

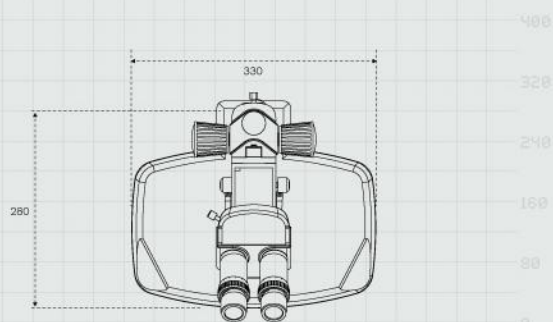
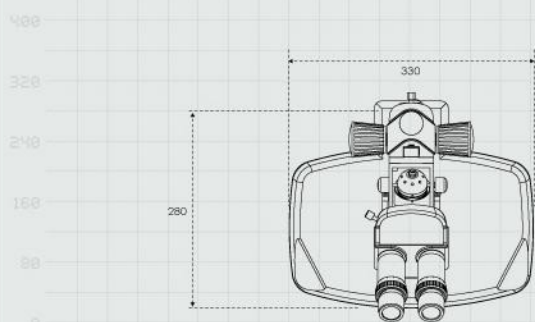
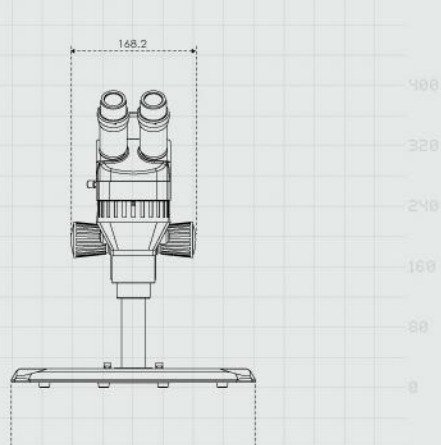
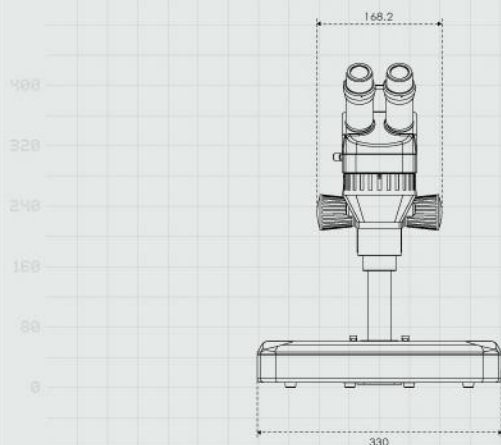
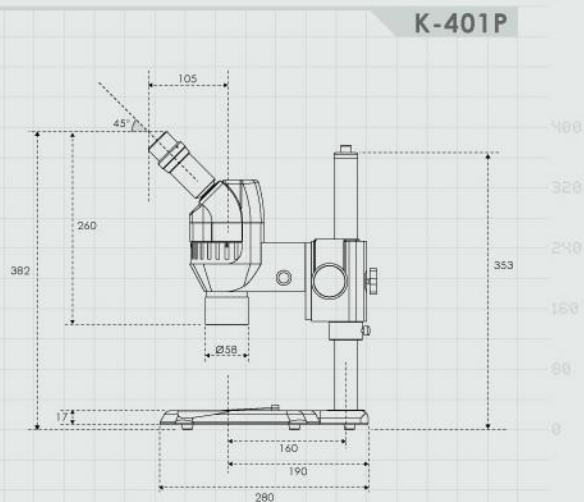

# K500 L/P Schematic Diagram

Unit:mm

K-500L

K-500P

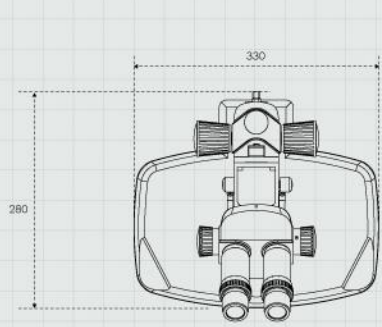
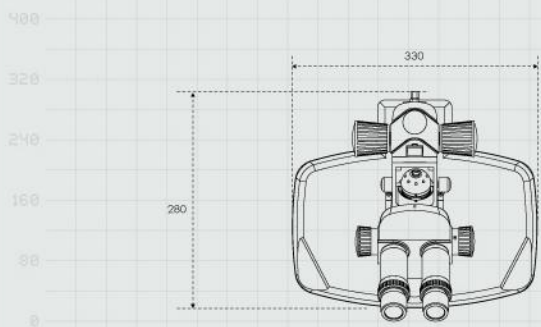
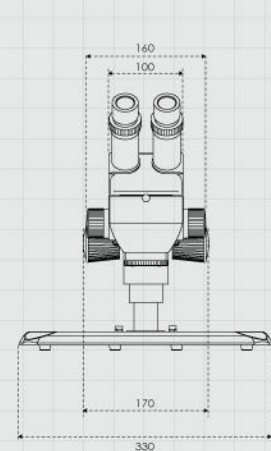
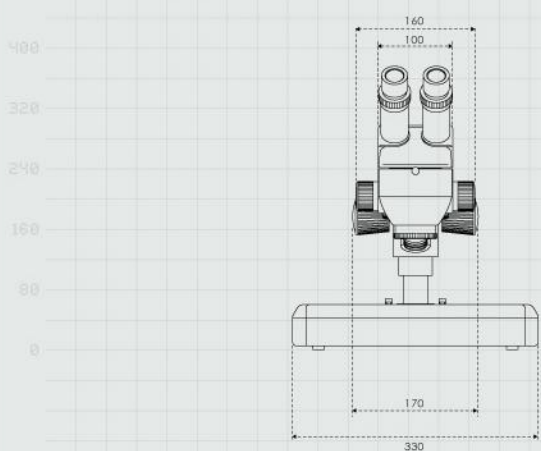
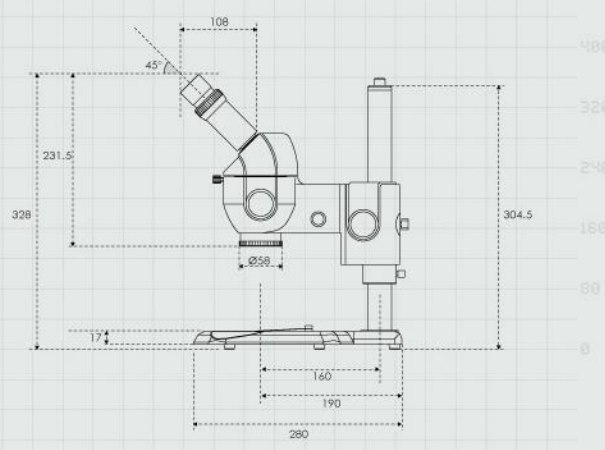
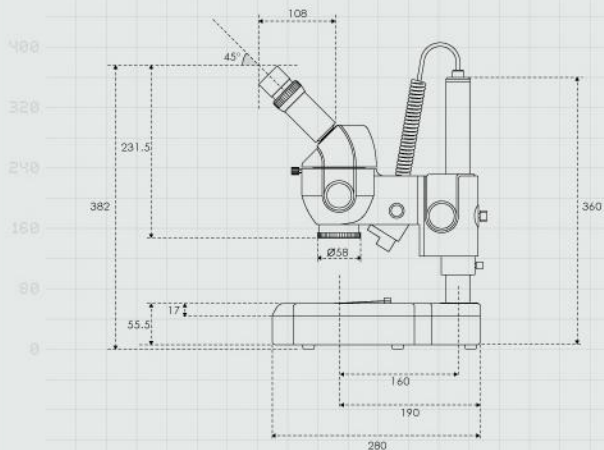



# Series

## K700 L/P Schematic Diagram

Unit:mm

### K-700L

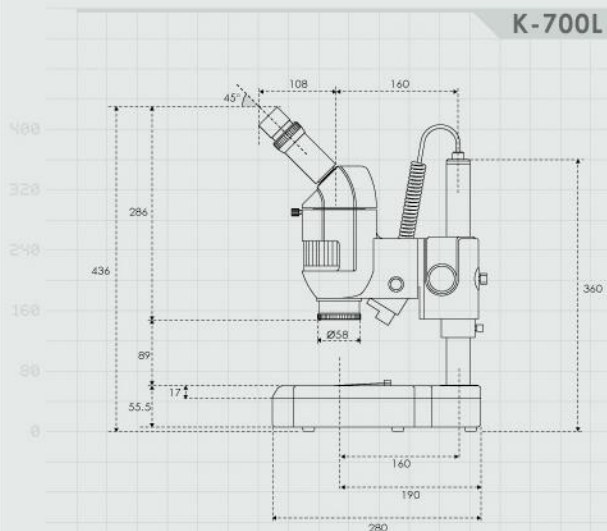

### K-700P

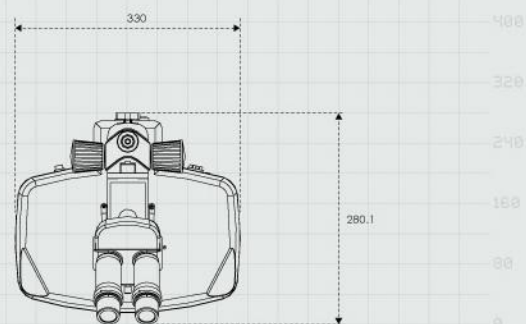
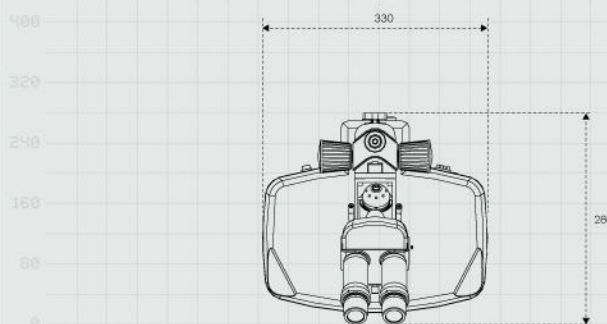
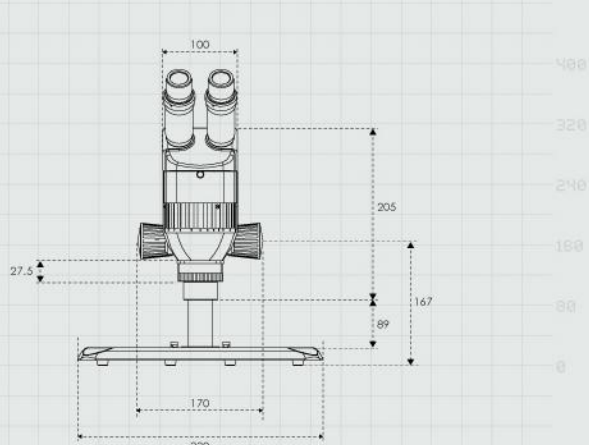
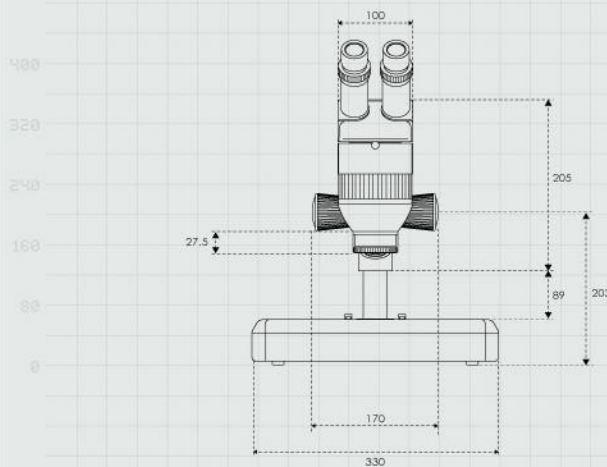
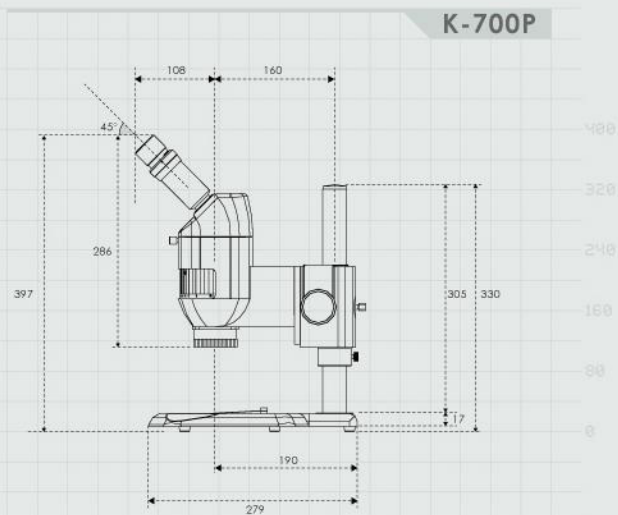

# DSM500 Schematic Diagram

# DSM700 Schematic Diagram

Unit:mm

DSK500

DSK700

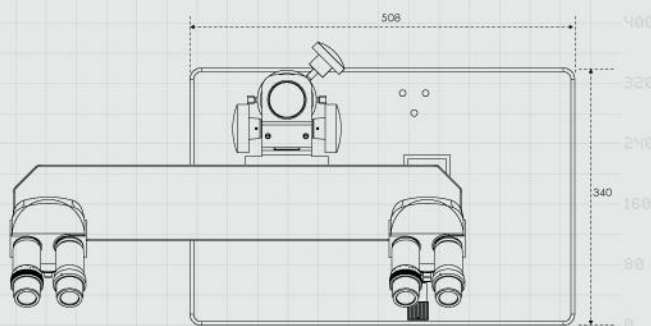
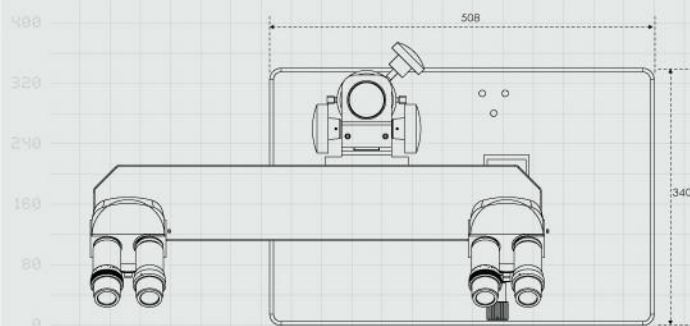
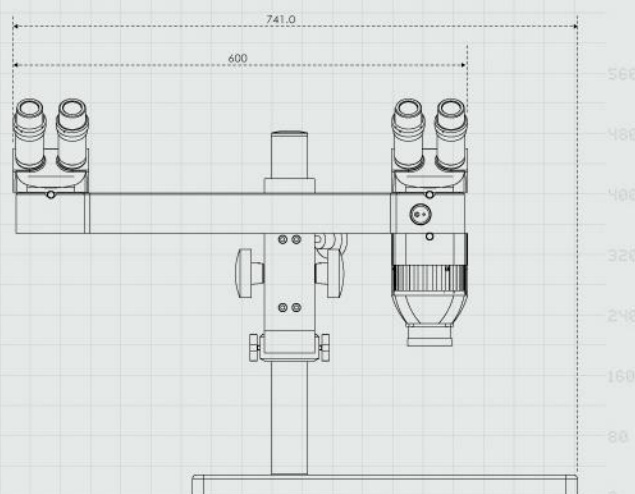
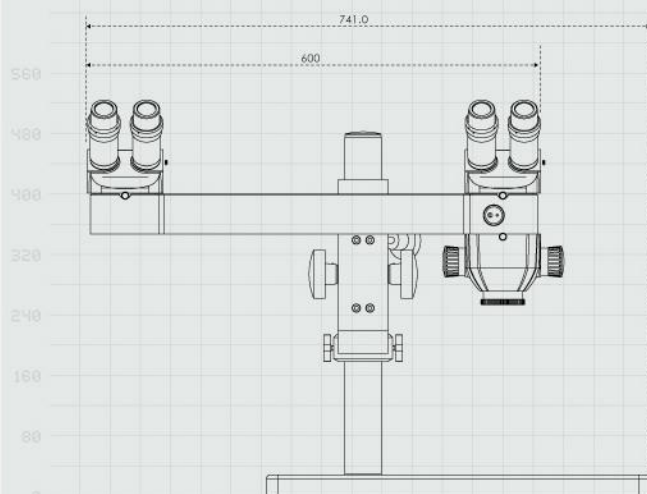
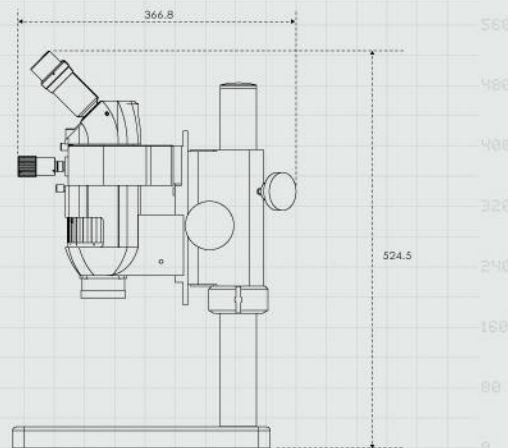
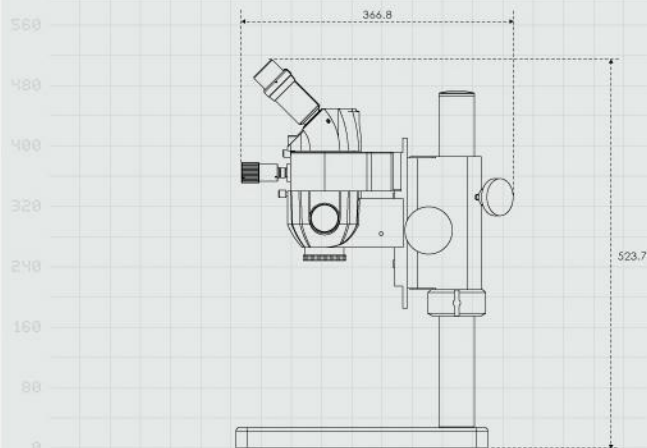

Unit:mm

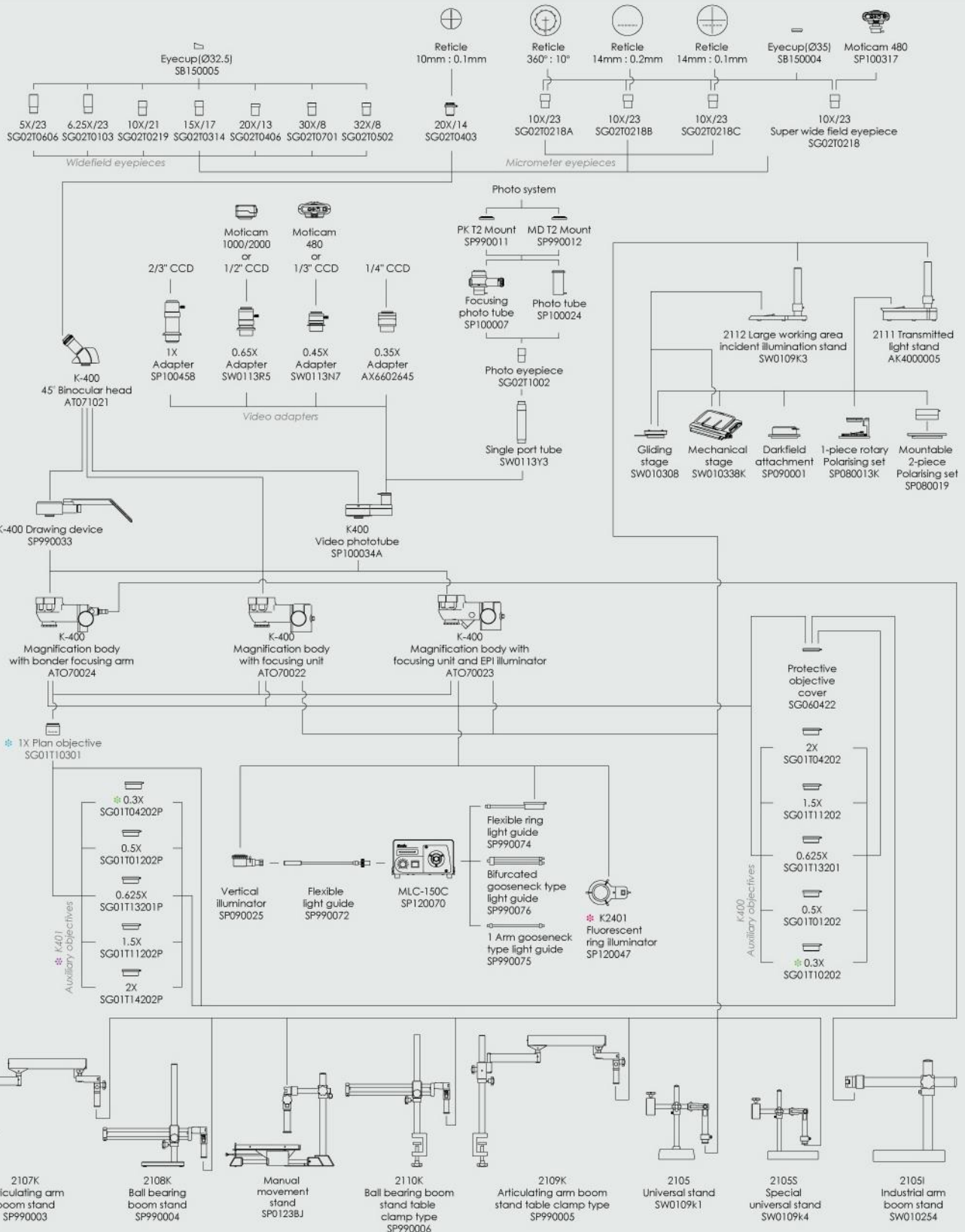

\* A pole height of 300mm is required with this objective when used.  
 \* When selecting the fluorescent ring illuminator, please note the country plug and voltage required.  
 \* 1X Plan objective must be selected when ordering complete unit  
 \* K401 Auxiliary Objectives can only be used in conjunction with the K401 Plan Achromatic system and cannot be interchanged with the K400 system.

# K500 System Diagram

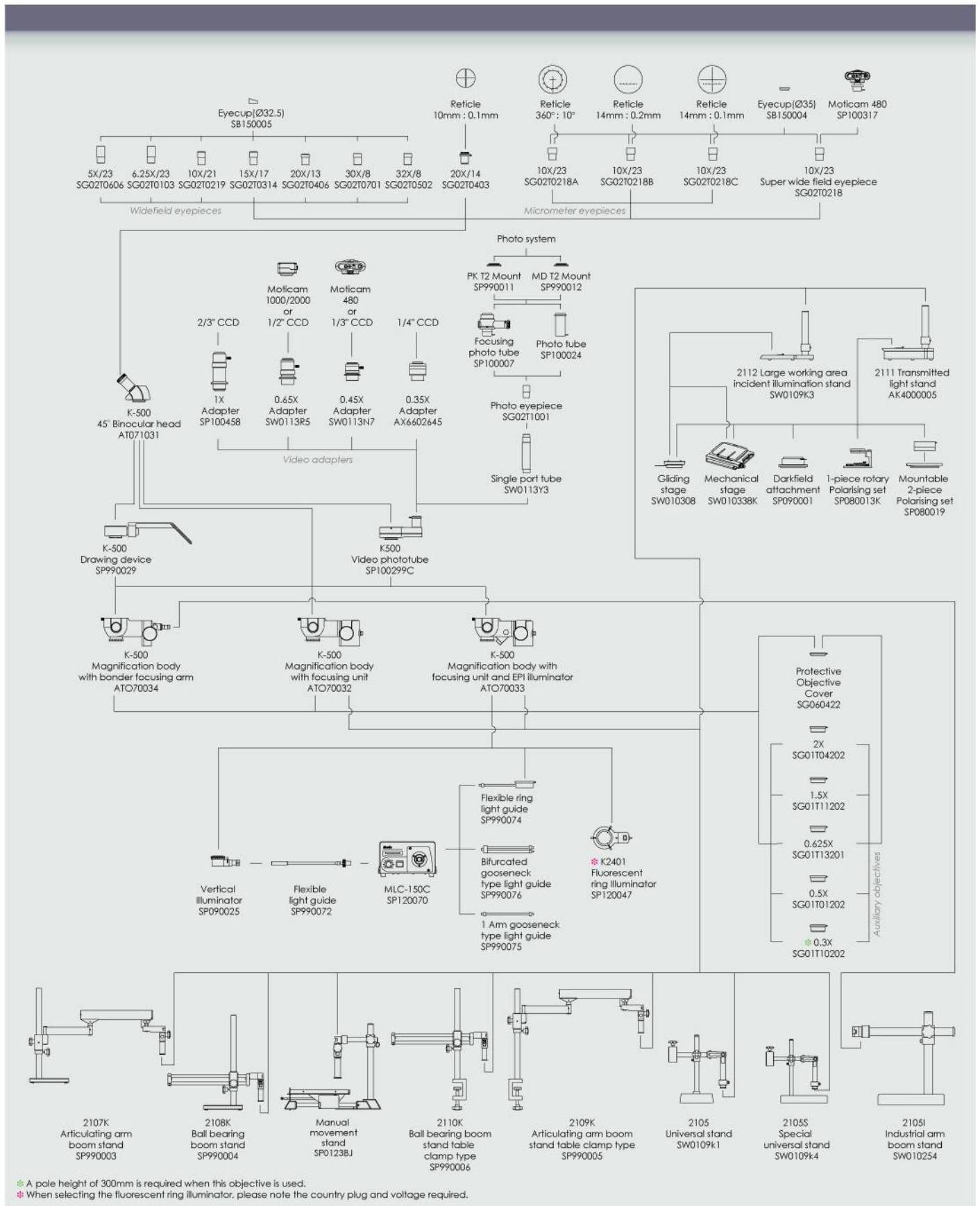

\* A pole height of 300mm is required when this objective is used.  
 \* When selecting the fluorescent ring illuminator, please note the country plug and voltage required.



# Series

## K700 System Diagram

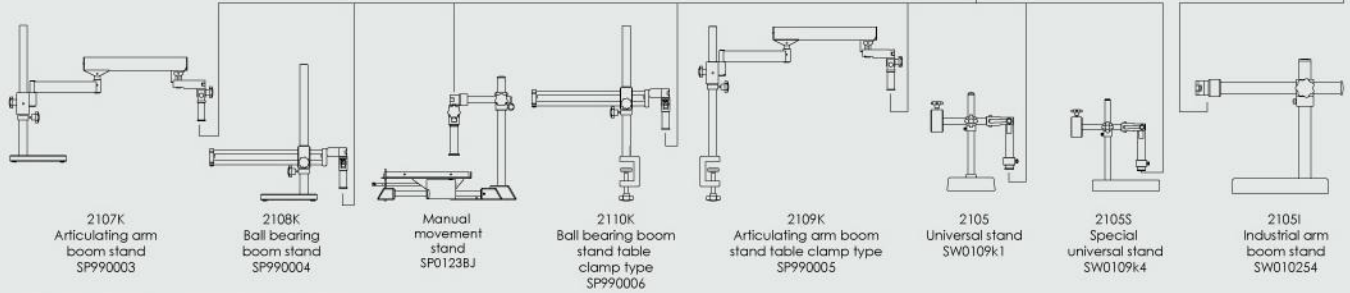
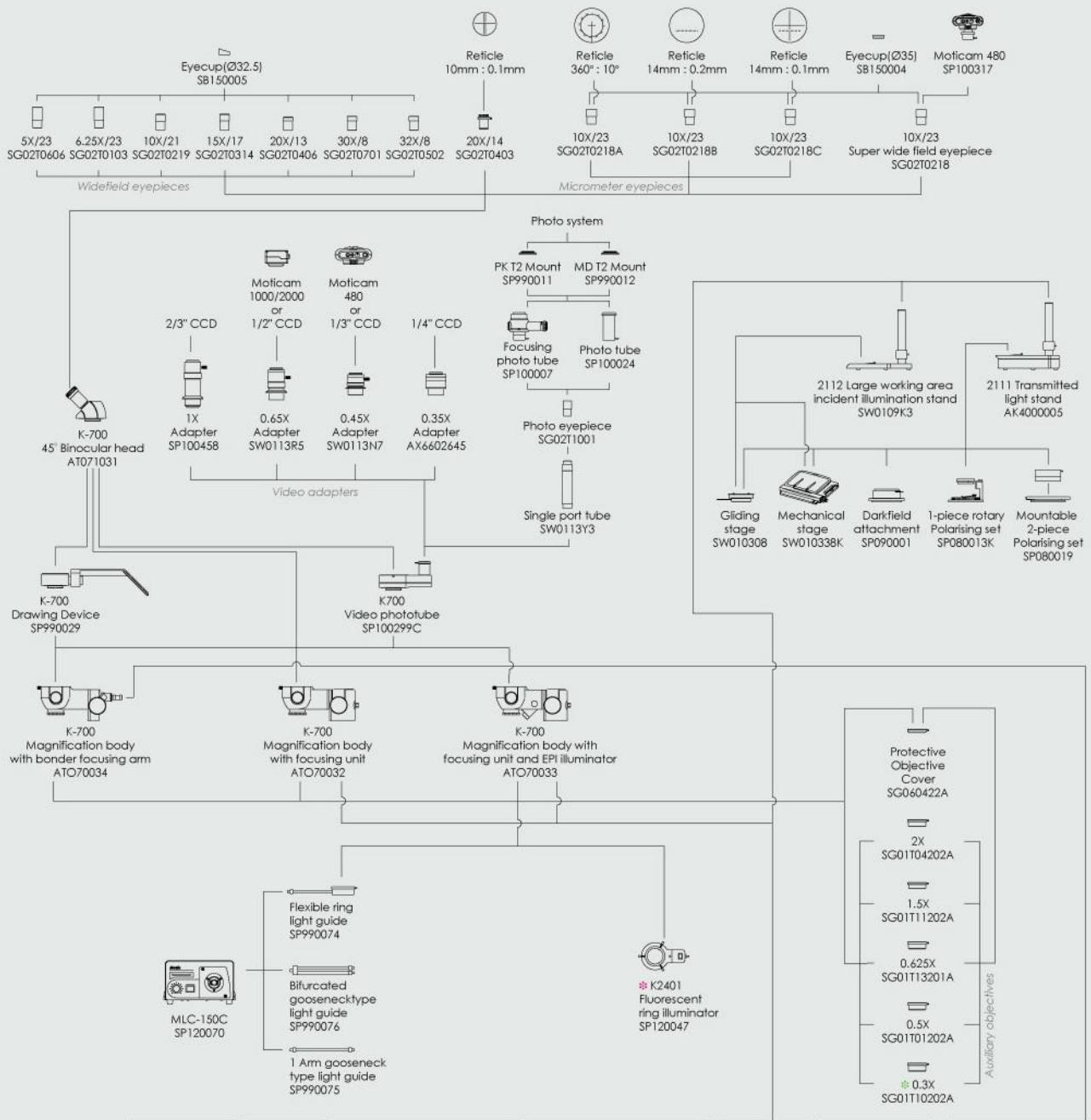

\* A pole height of 300mm is required when this objective is used.  
 \* When selecting the fluorescent ring illuminator, please note the country plug and voltage required.

## **Motic**® Microscopes

---

**Motic**®

---

[www.motic.com](http://www.motic.com)

**Motic Incorporation Ltd. (HONG KONG)**

Rm 2907-8, Windsor House, 311 Gloucester Road, Causeway Bay, Hong Kong  
Tel: 852-2837 0888 Fax: 852-2882 2792

**Motic Instruments Inc. (CANADA)**

180-4320 Viking Way Richmond, B.C. V6V 2L4 Canada  
Tel: 1-877-977 4717 Fax 1-604-303 9043

**For inquiries in UK (UK)**

Saracens House, 25 St. Margarets Green, Ipswich, IP4 2BN, Suffolk, UK  
Tel: 44-(0)-14732 81909 Fax 44-(0)-14732 11508

**Motic Deutschland GmbH (GERMANY)**

Gewerbepark Spilburg, Spilburgstrasse 1 D-35578 Wetzlar Germany  
Tel: 49-6441-210 010 Fax 49-6441-210 0122

**Motic Spain, S.L. (SPAIN)**

Poligon Industrial Les Corts, Camí del Mig, 112 08349 Cabrera de Mar Barcelona - Spain  
Tel: 34-93-756 6286 Fax: 34-93-756 6287

**Motic Incorporation Ltd. Copyright© 2002-2004. All Rights Reserved**

**Design Change:** The manufacturer reserves the right to make changes in instrument design in accordance with scientific and mechanical progress, without notice and without obligation.

CE



Code No: SP010737E